

# **Wood Stove**

*(Wood Burning  
Appliance) Compliance  
Review*

It is worth getting the job done right the first time.  
Your effort will pay off in peace of mind in the years to come

# Consideration

What type of  
Chimney and  
appliance

**SUPERVENT** Wood Stove Chimney & Double Wall Stove Pipe Planner *rather plan your system on line go to [www.supervent.com](http://www.supervent.com)* **EXCLUSIVE BLOWN-WALL INSTALLATION**

**Getting Started**

Before you begin, determine the (inner) diameter of your Chimney.



This is usually the same size (6", 7" or 8") as the flue collar on your wood stove.



**Need Help?**  
Contact us at:  
1.888.SELMIRK (735.5475)  
or visit us online at:  
[www.supervent.com](http://www.supervent.com)

**Step 1** Select type of installation by determining where your chimney will run and use this Work Sheet to plan your complete system. (Installations may vary, please refer to the respective installation @ [www.supervent.com](http://www.supervent.com))

**1 Decorator Ceiling Support Kit**

**Kit Includes:**  
1 Decorator Cap  
1 Plus Insulated Shell  
1 Ceiling Support  
1 Shoe Top Adapter



**Note:** If your Chimney runs more than 40" you must install a Roof Support.

**2 Cathedral Ceiling Support Kit**

**Kit Includes:**  
1 Shoe Top Cap  
1 Ceiling Support  
1 Shoe Top Adapter



**Note:** If your Chimney runs more than 18" you must install a Roof Support.

**3 Decorator Ceiling Support Kit with an Offset Installation**

**Kit Includes:**  
1 Shoe Top Cap  
1 Plus Insulated Shell  
1 Ceiling Support  
1 Shoe Top Adapter



**Note:** If your Chimney runs more than 40" you must install a Roof Support.

**4 Wall Support Kit**

**Kit Includes:**  
1 Shoe Top Cap  
2 Wall Panels  
1 Insulated Shell with Flue  
1 Wall Flange  
1 Shoe Top Adapter  
1 Adjustable Wall Support



**Note:** If your Chimney runs more than 22" you must install an Intermediate Wall Support.

**5 Wall Support Kit Through a Soffit Installation**

**Kit Includes:**  
1 Shoe Top Cap  
2 Wall Panels  
1 Insulated Shell with Flue  
1 Wall Flange  
1 Shoe Top Adapter  
1 Adjustable Wall Support



**Note:** If your Chimney runs more than 22" you must install an Intermediate Wall Support.

**SuperVent 2100 Parts Listing**

Part #	PRICE	QTY	TOTAL
1 Decorator Ceiling Support Kit	JM*CCSP	\$	X
2 Cathedral Ceiling Support Kit	JM*CCSK	\$	X
3 Wall Support Kit	JM*WSP	\$	X
Chimney Lengths (See Step 2)			
36" length	JM*CS36	\$	X
24" length	JM*CS24	\$	X
18" length	JM*CS18	\$	X
12" length	JM*CS12	\$	X
6" length	JM*CS6	\$	X
Locking Band (1 for every 5' above roof)	JM*SLB	\$	X
Second Attic Shield for 2 Storey Install	JM*AIS	\$	X
Roof Flashing Assembly with Storm Collar (see Step 3)	JM*AAF	\$	X
Roof Flashing Assembly with Storm Collar (see Step 3)	JM*AF2	\$	X
Rubber Boot Flashing Kit	JURBFK2	\$	X
Roof Guy Kit if Chimney is 5' above roof.	JURGK-1	\$	X
Chimney Offset Kit (if req'd)	JM*SEK	\$	X
Chimney Offset Kit (if req'd)	JM*SEK	\$	X
Universal Shielding Insulation	JUS	\$	X

**Blow-Through Double Wall Stove Pipe Parts Listing**

Part #	PRICE	QTY	TOTAL
Universal Chimney Adapter	DSP*CA	\$	X
Telescopic Length	DSP*TL	\$	X
Adjustable Length	DSP*AL1	\$	X
Fixed Lengths:			
6"	DSP*P6-1	\$	X
12"	DSP*P12-1	\$	X
24"	DSP*P24-1	\$	X
36"	DSP*P36-1	\$	X
Finishing Band	DSP*FB	\$	X
Reducer			
6"-7"	DSPR67	\$	X
7"-8"	DSPR78	\$	X
6"-8"	DSPR68	\$	X
7"-6"	DSPR76	\$	X
8"-7"	DSPR87	\$	X
8"-8"	DSPR88	\$	X
45° Elbow	DSP*E41	\$	X
90° Elbow	DSP*E91	\$	X
Tea Section	DSP*TE-1	\$	X
Damper Kit	DSP*DK-1	\$	X
Stove Adapter	DSP*SA-1	\$	X

**NOTE:** Asterisk "\*" shown in part # represents Decorator required.

# What to start with First in Determining your Installation

- What Size of Home Sq Ft or M2
- Will determine size and model of appliance
- Location of Installation in Home
- Size of Flue Pipe- Why
- Certified Appliance or Not



**Product Testing and**

**Certification Agencies**

**Regulation**

## Two Main Organization that write Standards for Solid Fuels Burning Appliances are:

1. Underwriters Laboratories of Canada (ULC)
2. Canadian Standards Association (CSA)

**Certified appliances carry a label with the logo of the certification agency.** They are your assurance that the product has been tested and conforms to safety standards.

As part of the certification process, the **manufacturer's installation instructions are checked and approved.** They must also contain certain basic information and messages. You can rely on these certified installation instructions to be accurate. When followed, they will result in a safe installation. Look for these logos when you are shopping for a wood-burning appliance.



# Product Testing and Certification Agencies.

These three agencies test wood-burning appliances for safety in Canada

CSA International (formerly the Canadian Standards Association)



Underwriters' Laboratories of Canada



Intertek Testing Services, Ltd. (formerly Warnock Hersey Professional Services Ltd.)





US ENVIRONMENTAL PROTECTION  
AGENCY PHASE II CERTIFIED  
WOODSTOVES

Vérifié et testé suivant  
ULC S627 et UL 1482 Standards by:

Intertek Testing Services  
Warnock Hersey

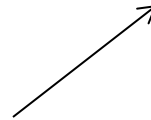

**SYMBOLS**

# Treatment of Certified Versus Uncertified Appliances



# Treatment of Certified Versus Uncertified Appliances

A certified appliance, accessory, component and equipment shall be installed in accordance with the **manufacturer's installations instructions**. When a difference exists between the manufactures instructions and the requirements of this CAN/CSA B365 standards, the installation instructions shall govern.

WH-

DO NOT REMOVE THIS LABEL

WH-

WARNOCK HERSEY

REPORT NO.  
5041 (MAY, 99)

CERTIFIED FOR CANADA AND U.S.A.  
LISTED ROOM HEATER, SOLID FUEL TYPE.  
ALSO FOR USE IN MOBILE HOMES  
TESTED TO CAN/ULC S627-M90 AND UL 1482-98

MODEL SERIES D: ■ SUPER 27 ■ SPECTRUM ■ CLASSIC

- INSTALL AND USE IN ACCORDANCE WITH THE MANUFACTURER'S INSTALLATION AND OPERATING INSTRUCTIONS.
- CONTACT LOCAL BUILDING OR FIRE OFFICIALS ABOUT RESTRICTIONS, INSTALLATION PERMIT AND INSPECTION IN YOUR AREA.
- DO NOT CONNECT THIS UNIT TO A CHIMNEY FLUE SERVING ANOTHER APPLIANCE (USA, ONLY).
- USE 6 INCH / 150MM DIAMETER MINIMUM 24 MSG BLACK OR LISTED CONNECTOR.
- CONNECT TO A LINED MASONRY CHIMNEY SUITABLE FOR USE WITH SOLID FUELS.
- DO NOT OBSTRUCT THE SPACE BENEATH THE HEATER.
- SEE LOCAL BUILDING CODE AND MANUFACTURER'S INSTRUCTIONS FOR PRECAUTIONS REQUIRED WHEN PASSING A CHIMNEY THROUGH A COMBUSTIBLE WALL OR CEILING.
- DO NOT PASS A CHIMNEY CONNECTOR THROUGH A COMBUSTIBLE WALL OR CEILING.
- MINIMUM CLEARANCE BETWEEN SINGLE WALL CHIMNEY CONNECTOR AND COMBUSTIBLE MATERIALS-19INCHES/ 455MM. CLEARANCE MAY BE REDUCED BY THE USE OF LISTED PIPE SHIELDS, WALL PROTECTORS OR OTHER MEANS APPROVED BY LOCAL BUILDING OR FIRE OFFICIALS.

## MINIMUM CLEARANCES TO COMBUSTIBLE MATERIALS

	RESIDENTIAL INSTALLATION USING SINGLE WALL CONNECTOR		RESIDENTIAL CLOSE CLEARANCE INSTALLATION USING DOUBLE WALL CONNECTOR		* ALCOVE INSTALLATION USING DOUBLE WALL CONNECTOR	MOBILE HOME INSTALLATION USING DOUBLE WALL CONNECTOR
	VERTICAL CONNECTOR	HORIZONTAL CONNECTOR	VERTICAL CONNECTOR	HORIZONTAL CONNECTOR		
A. SIDEWALL TO UNIT	18 in. / 455 mm	14 in. / 355 mm	14 in. / 355 mm	14 in. / 405 mm	16 in. / 405 mm	16 in. / 405 mm
B. BACKWALL TO UNIT	12 in. / 305 mm	8 in. / 200 mm	5 in. / 127 mm	8 in. / 200 mm	10 in. / 255 mm	8 in. / 200 mm
C. CORNER TO UNIT	11 in. / 280 mm	11 in. / 280 mm	4 in. / 102 mm	8 in. / 200 mm	N/A	8 in. / 200 mm
D. SIDEWALL TO CONNECTOR	27 in. / 685 mm	23 in. / 585 mm	22.5 in. / 570 mm	22.5 in. / 570 mm	24.5 in. / 620 mm	24.5 in. / 620 mm
E. BACKWALL TO CONNECTOR	19 in. / 485 mm	15 in. / 380 mm	11.5 in. / 292 mm	14.5 in. / 370 mm	16.5 in. / 420 mm	14.5 in. / 370 mm
F. CORNER TO CONNECTOR	22 in. / 560 mm	22 in. / 560 mm	14.5 in. / 470 mm	18.5 in. / 470 mm	N/A	18.5 in. / 470 mm

HORIZONTAL CONNECTOR NOT PERMITTED IN MOBILE HOMES

- AS TESTED - PIPE SHIELD MAY BE REQUIRED BY LOCAL AUTHORITIES.
- COMBUSTIBLE ALCOVE SIZE : DEPTH - 4 FT. / 1.22 M MAXIMUM, HEIGHT 7 1/2 FT. / 2.3 M MINIMUM
- COMBUSTIBLE FLOOR MUST BE PROTECTED BY A CONTINUOUS NON-COMBUSTIBLE MATERIAL EXTENDED TO THE FRONT, SIDES AND BACK AS INDICATED.

IN CANADA	G.	18 INCHES / 455 MM
	H.	8 INCHES / 200 MM
	I.	8 INCHES / 200 MM
IN U.S.A.	G.	16 INCHES / 405 MM
	H.	5 INCHES / 127 MM
	I.	0 INCHES / 0 MM

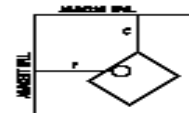
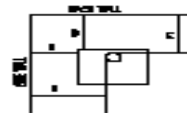
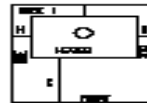

- COMPONENTS REQUIRED FOR MOBILE HOME AND ALCOVE INSTALLATION: OUTSIDE AIR KIT, AND ONE OF THE FOLLOWING LISTED CONNECTORS: SECURITY MODELS DP OR DC, OLIVER MACLEOD MODEL PV, ENERGY VENT E VENT, SELKIRK METALBESTOS MODEL DS, METAL FAB MODEL DW, AMERI-TEC MODEL DBSP, OR INDUSTRIAL CHIMNEY MODEL EXCEL ULTRA-BLACK IN COMBINATION WITH ONE OF THE FOLLOWING COMPATIBLE CHIMNEY SYSTEMS: APPLIANCE MUST BE INSTALLED WITH PEDESTAL OR LEG KIT ATTACHED.
- IN CANADA - SECURITY MODEL S2100, OLIVER MACLEOD PROJET MODEL HT 2000, SELKIRK SENTINEL MODEL CF, INDUSTRIAL CHIMNEY MODEL EXCEL 2100.
- IN USA - SECURITY MODEL ASHT OR S2100, OLIVER MACLEOD MODEL 3103 OR HT 3000, SELKIRK METALBESTOS MODEL SS II, METAL FAB MODEL 2100, AMERI-TEC MODEL HS, INDUSTRIAL CHIMNEY MODEL EXCEL 103HT.
- USE COMPONENTS SPECIFIED IN PACIFIC ENERGY INSTALLATION INSTRUCTIONS.
- OPTIONAL COMPONENTS - WATER COIL (CANADA ONLY), FAN KIT #SSER.BLOW, FAN ELECTRICAL RATING: 115V, 60HZ, 80WATTS. DO NOT ROUTE POWER CORD BENEATH HEATER.
- CAUTION: RISK OF EXCESSIVE TEMPERATURES - KEEP ASH DUMP CLOSED DURING FIRING OF THE HEATER.
- OPERATE ONLY WITH FEED DOOR CLOSED. OPEN TO FEED FIRE ONLY.
- KEEP FURNISHINGS AND OTHER COMBUSTIBLE MATERIALS WELL AWAY FROM HEATER.
- REPLACE GLASS ONLY WITH CERAMIC GLASS.

**CAUTION**

HOT WHILE IN OPERATION. DO NOT TOUCH. KEEP CHILDREN, CLOTHING AND FURNITURE AWAY. CONTACT MAY CAUSE SKIN BURNS. SEE NAMEPLATE AND INSTRUCTIONS.

**PACIFIC ENERGY**

MANUFACTURED BY:  
PACIFIC ENERGY FRIEPLACE PRODUCTS LTD.  
P.O. BOX 1060, QUINCY, BC V1L 3Y2

U.S. ENVIRONMENTAL PROTECTION  
AGENCY CERTIFIED TO COMPLY WITH  
JULY, 1990, PARTICULATE EMISSION  
STANDARDS

240499

5050.75

**MADE IN CANADA**

DATE OF MANUFACTURE

J	F	M	A	M	J	J	A	S	O	N	D
1999		2000	2001	2002	2002	2003	2003	2004			

SUP1-A1

# Protection for the Floor

- Wood stoves that are certified as meeting the safety test standard will not overheat a combustible floor. During Testing, The Floor Temperature Is Checked And Must Not Exceed Safe Limits. Although the floor will not overheat due to stove operation, the floor must be protected from live embers that might fall from the stove during fire tending or ash removal. The floor pad must be made of a durable, noncombustible material, **such as sheet metal**, grouted ceramic tile, or mortared brick.
- Floor pads must normally extend **not less than 450 mm (18 in.)** in front of the loading door and **200 mm (8 in.) beyond the other sides and back**. Floor pads must not be installed on carpet unless the pad is structurally supported so that it does not move or distort.
- Uncertified appliances have not passed safety tests, so heat from the bottom may overheat floors. The rules for floor protection for uncertified appliances are complicated, with several different types depending on how high the legs support the stove from the floor.
- If you are installing an uncertified appliance, you should contact a qualified professional for details.

# Radiant Uncertified Appliances

Uncertified appliances have not passed safety tests, so heat from the bottom may overheat floors. The rules for floor protection for uncertified appliances are complicated, with several different types depending on how high the legs support the stove from the floor.

If you are installing an uncertified appliance, you should contact a qualified professional for details.

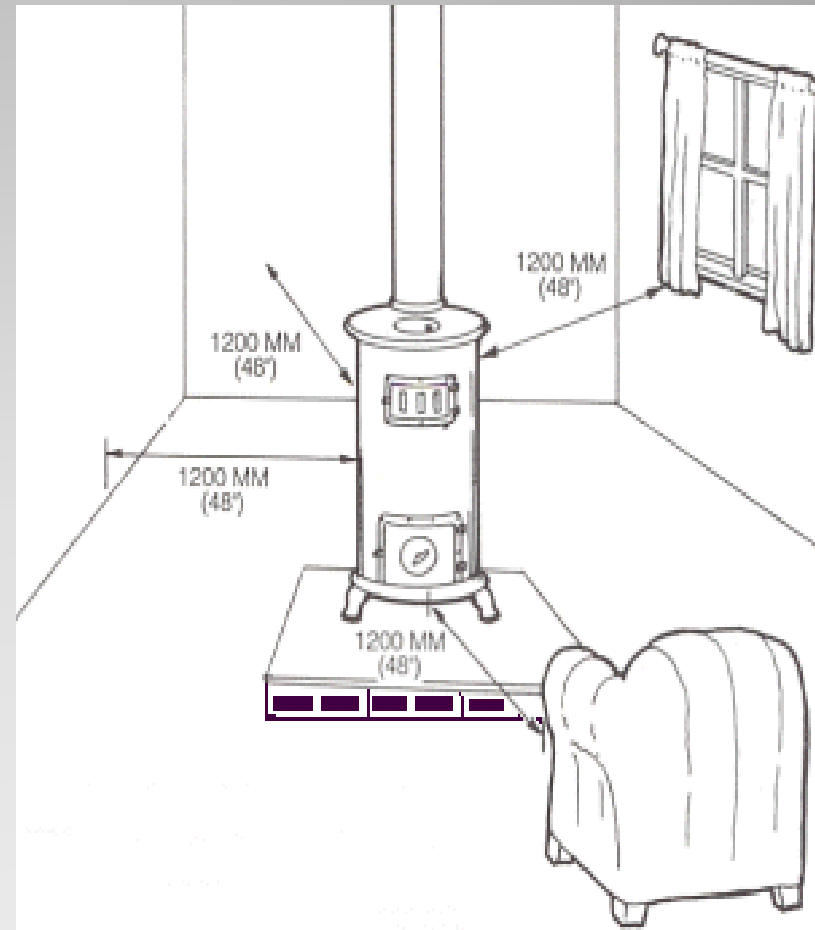

# Side and Rear Wall Clearance for an Uncertified Stove

## Clearances to Combustible Material for Appliances Using Solid Fuel

Source: CAN/CSA International B365-10, Table 2

Application	Minimum clearance, mm (in.)		
	Top	Sides, rear and corner	Fuelling and ash removal side(s)
Appliances with no shielding*	1500 (60)	1200 (48)	1200 (48)
Appliances with shielding*	1500 (60)	900 (36)	1200 (48)

\* Shielding consists of protection such as external jacketing or a metal heat shield attached to the sides and rear of the appliance and spaced out at least 50 mm (2 in.) by non-combustible spacers, with provision for air circulation at bottom and top.

**Note:** Clearances shall be measured from the outer surface of the appliance to the combustible material; a non-combustible covering applied over the combustible material shall be disregarded.

The manufacturer's installation instructions specify the right clearances for the appliance. The clearances for certified appliances vary, but are less than those shown in the following table (from CSA B365) for uncertified appliances. Many of the new, certified appliances have heat shields on the sides and rear, reducing clearances by as much as 90 percent.

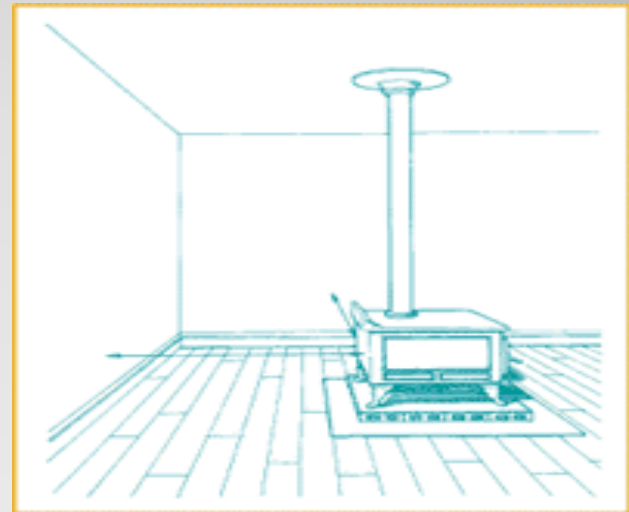

# *Shield Construction Rules*

- *Minimum space between shield and combustibles: 21 mm (7/8 in.).*
- *Minimum clearance along the bottom of shield: 25 mm (1 in.).*
- *Maximum clearance along the bottom of shield: 75 mm (3 in.).*
- *Minimum clearance along the top of shield at ceiling: 75 mm (3 in.).*
- *Shield extension beyond each side of appliance: 450 mm (18 in.).*
- *Shield extension above appliance: 500 mm (20 in.).*
- *Edge clearance for ceiling shields: 75 mm (3 in.).*
- *Adhesives used in shield construction must not ignite or lose adhesive qualities at temperatures likely to be encountered.*
- *Mounting hardware must allow full vertical ventilation.*
- *Mounting hardware must not be located closer than 200 mm (8 in.) from the vertical centre line of the appliance.*
- *Mounting hardware which extends from the shield surface into combustibles may be used only at the lateral extremities of the shield*

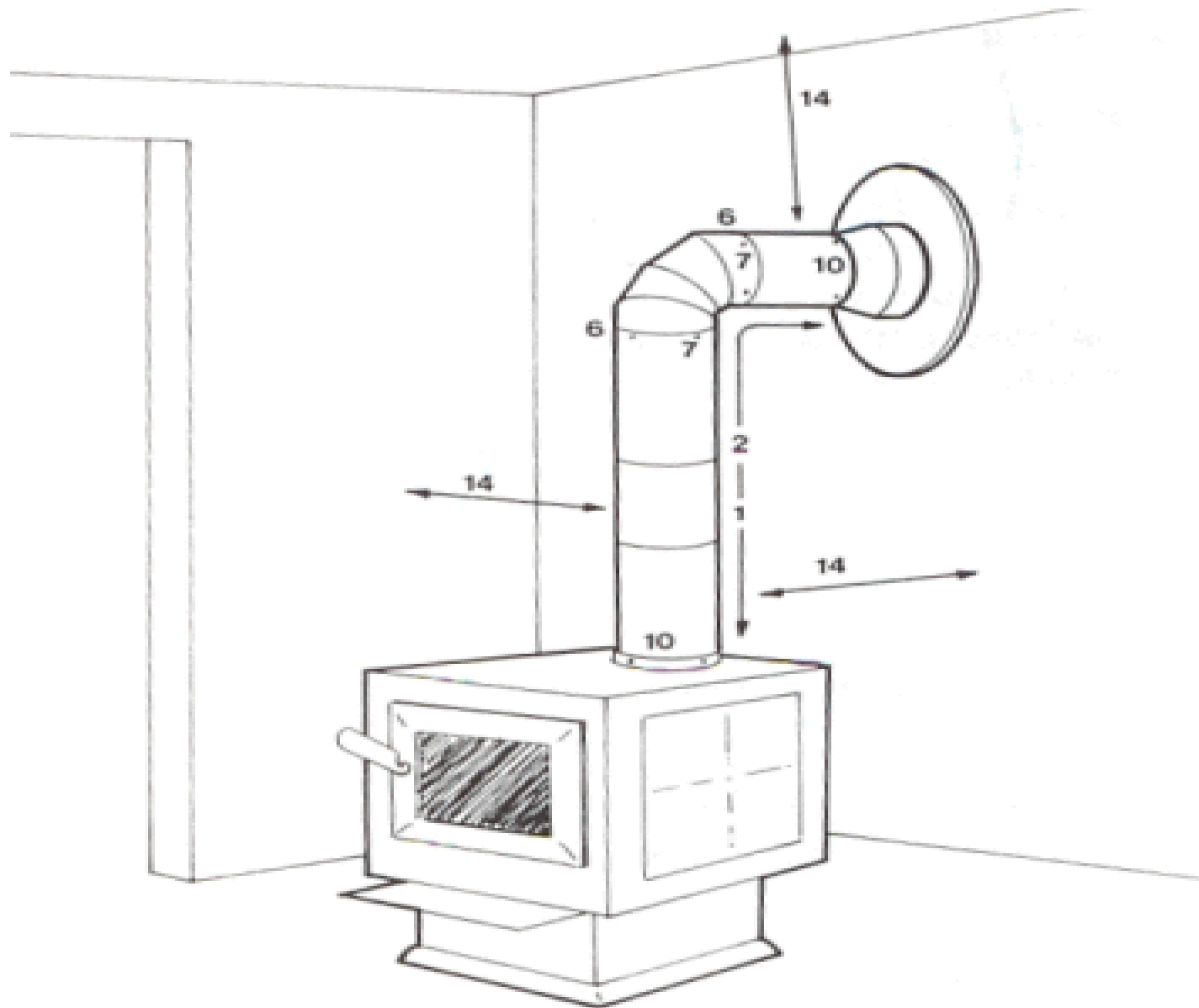



# WALL SHIELD ASSEMBLY

*By allowing air to flow between the shield and the combustible surface, a wall shielding assembly can be used to safely reduce minimum clearances. The shield is required to extend at least 500 mm (20 in.) above the top of the appliance and 450 mm (18 in.) beyond each edge of the appliance.*

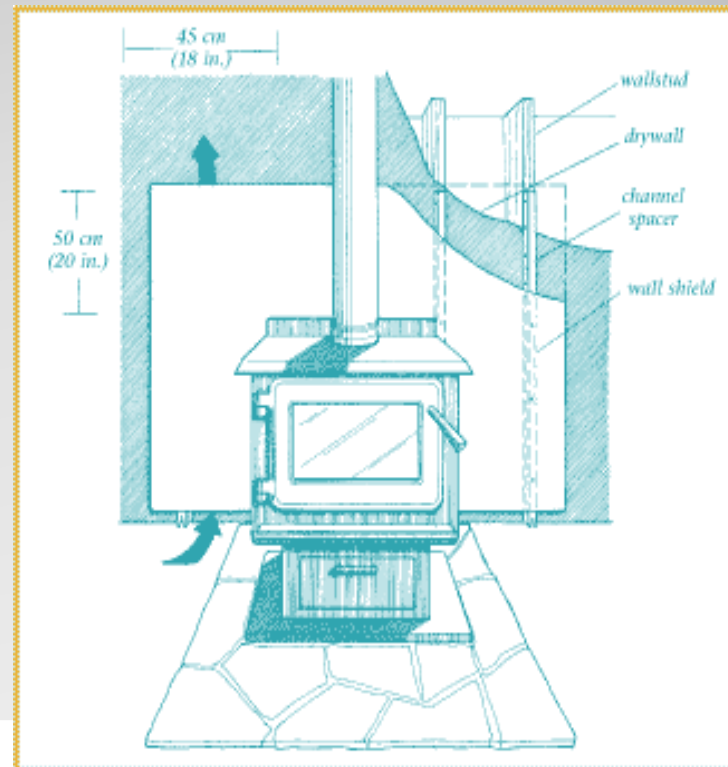



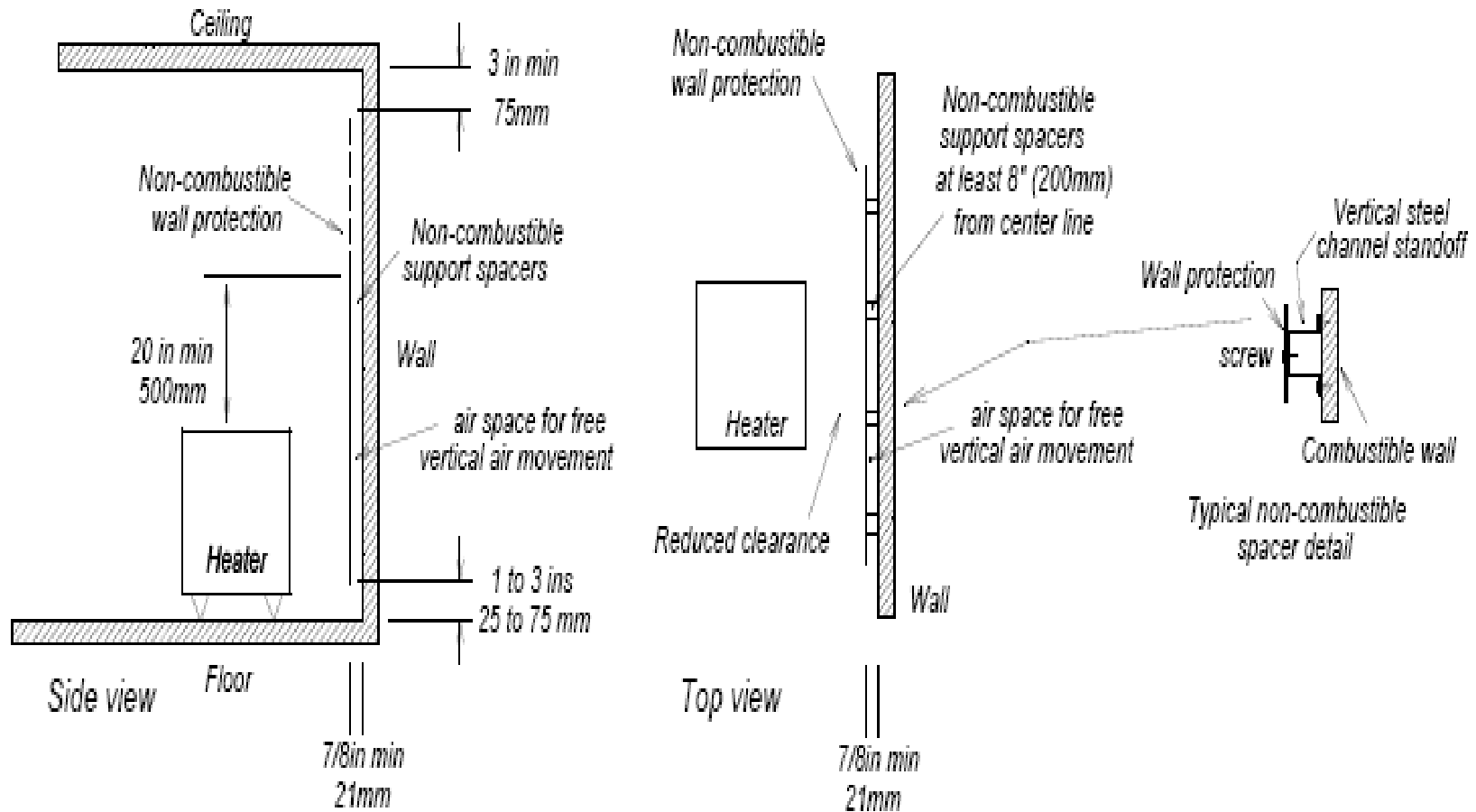

TYPICAL SIDE-WALL PROTECTION FOR CLEARANCE REDUCTION OF 50%

### Reducing Clearances with Shielding

Source: CSA 365-01, Table 3, Reduction in Appliance and Ductwork Clearance from Combustible Material with Specified Forms of Protection

Clearances may be reduced by these percentages

#### Type of protection (shield)

	Sides and rear %	Top %
Sheet metal, a minimum of 29 gauge in thickness spaced out at least 21 mm (7/8 in.) by non-combustible spacers	67	50
Ceramic tiles or equivalent non-combustible material on non-combustible supports spaced out at least 21 mm (7/8 in.) by non-combustible spacers	50	33
Ceramic tiles or equivalent non-combustible material on non-combustible supports with a minimum of 29 gauge sheet metal backing spaced out at least 21 mm (7/8 in.) by non-combustible spacers	67	50
Brick spaced out at least 21 mm (7/8 in.) by non-combustible spacers	50	n/a
Brick with a minimum of 29 gauge sheet metal backing spaced out at least 21 mm (7/8 in.) by non-combustible spacers	67	n/a

# ***THE IDEAL SINGLE-WALL FLUE PIPE ASSEMBLY***

*When the flue gas path is straight, the system will produce stronger draft and will need less maintenance than if the assembly has elbows. The ideal flue pipe assembly rises straight from the appliance flue collar into the chimney. A straight single-wall flue pipe assembly needs an inspection wrap or telescopic section so it can be installed and removed without having to move the appliance. The wrap also allows some movement for expansion when the flue pipe gets hot.*

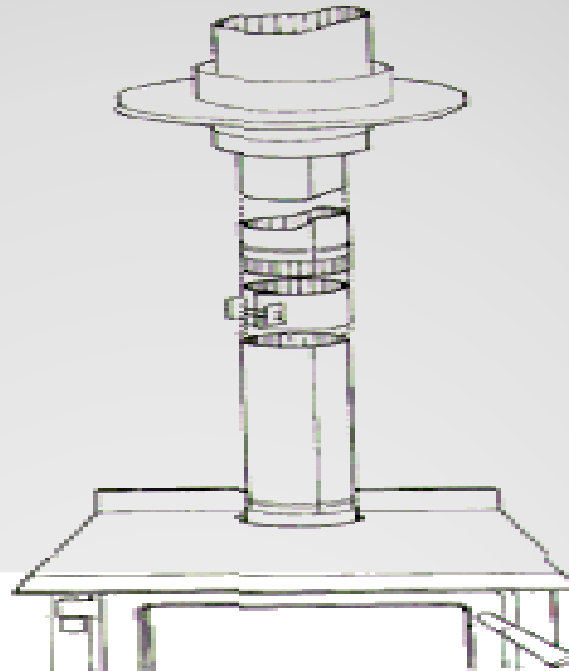

# Rules for Single-Wall Flue Pipe Assemblies

- *Minimum clearance from combustible material: 450 mm (18 in.).*
- *The minimum clearance may be reduced by 50 percent to 225 mm (9 in.) if suitable shielding is installed either on the pipe or on the combustible surface.*
- *Maximum overall length of straight pipe: 3 m (10 ft.)*
- *Maximum unsupported horizontal length: 1 m (3 ft.).*
- *Maximum number of 90-degree elbows: 2*
- *Minimum upward slope towards the chimney: 20 mm/m (1/4 in/ft.).*
- *The crimped ends (male) of the sections must be oriented towards the appliance.*
- *Each joint in the assembly must be fastened with at least three screws, including the connections at the appliance flue collar and chimney.*
- *6-, 7-, and 8-inch diameter flue pipes must be at least 24 gauge in thickness.*
- ***Galvanized flue pipes must not be used because the coatings vaporize at high temperatures and release dangerous gases. Use black painted flue pipes.***
- *The assembly must have allowance for expansion: elbows in assemblies allow for expansion; straight assemblies should include an inspection wrap with one end unfastened, or a telescopic section.*

# Certified double-wall flue pipe systems

- The minimum installation clearances for certified double-wall flue pipes are much less than those for single-wall pipes. Also, the maximum length of a double-wall flue pipe assembly may be greater than is permitted for a single-wall pipe.
- There are two general types of double-wall flue pipes: sealed and vented. A sealed double-wall flue pipe is effective at retaining the heat in the flue gases because the air space between the inner liner and outer shell acts as an insulator.

## DOUBLE WALL vs SINGLE WALL STOVE PIPE

Product	Tested & Labeled	Material	Clearances to Combustibles	Warranty
Model DSP Double Wall Stove Pipe	To ULC S641 / UL 103	Heavy Gauge Stainless Steel / Aluminized Steel	6 Inches	Lifetime Warranty
Single Wall Stove Pipe	Not Tested or Labeled	Light Gauge Carbon Steel	18 Inches	* No Warranty

\* If a wood burning appliance is used every day in the heating season, surveys have shown that a single wall stove pipe will need replacement every two or three years.

## VERTICAL INSTALLATION

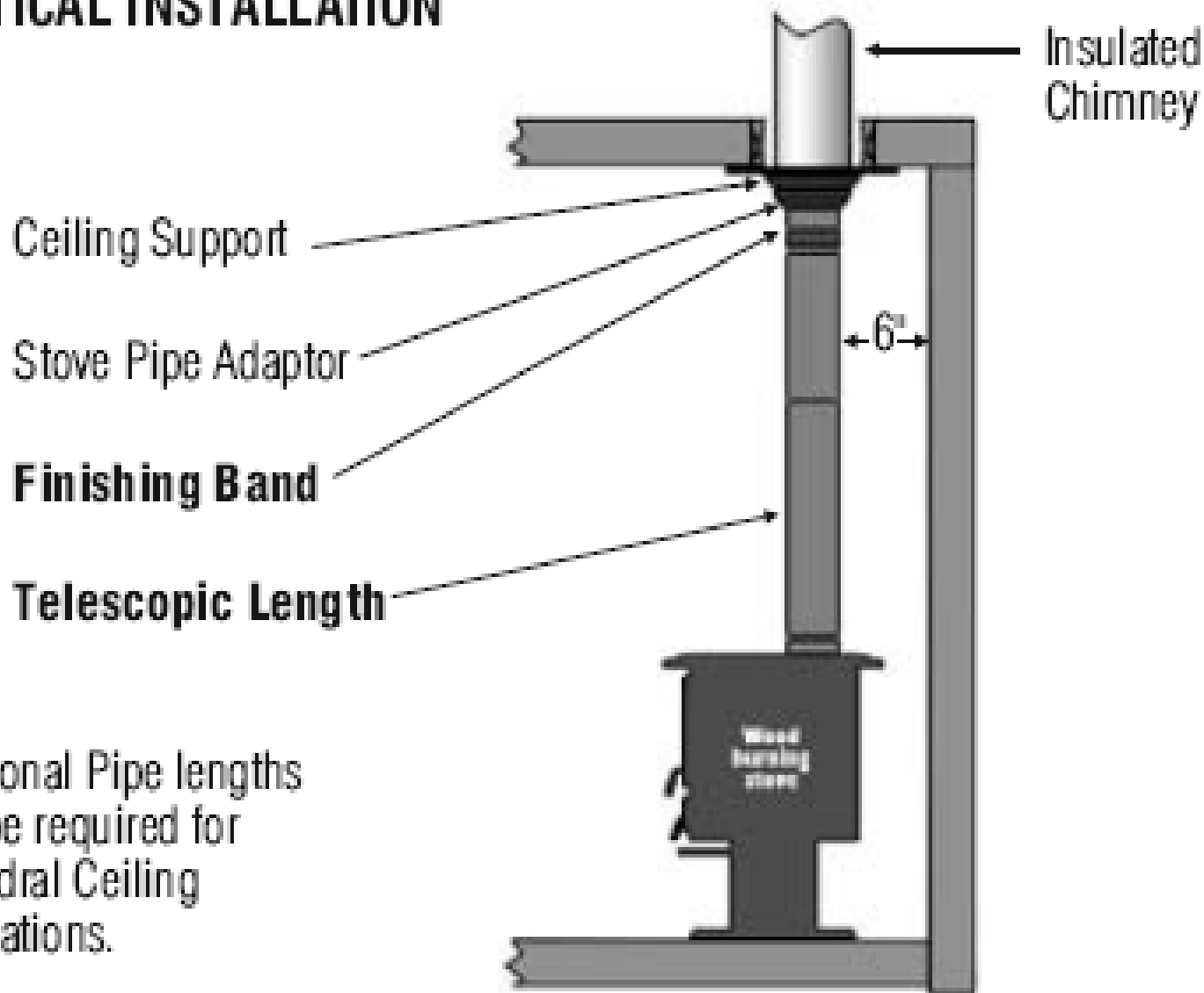

Additional Pipe lengths  
may be required for  
Cathedral Ceiling  
Installations.

# INSTALLATION WITH A CLEAN-OUT TEE

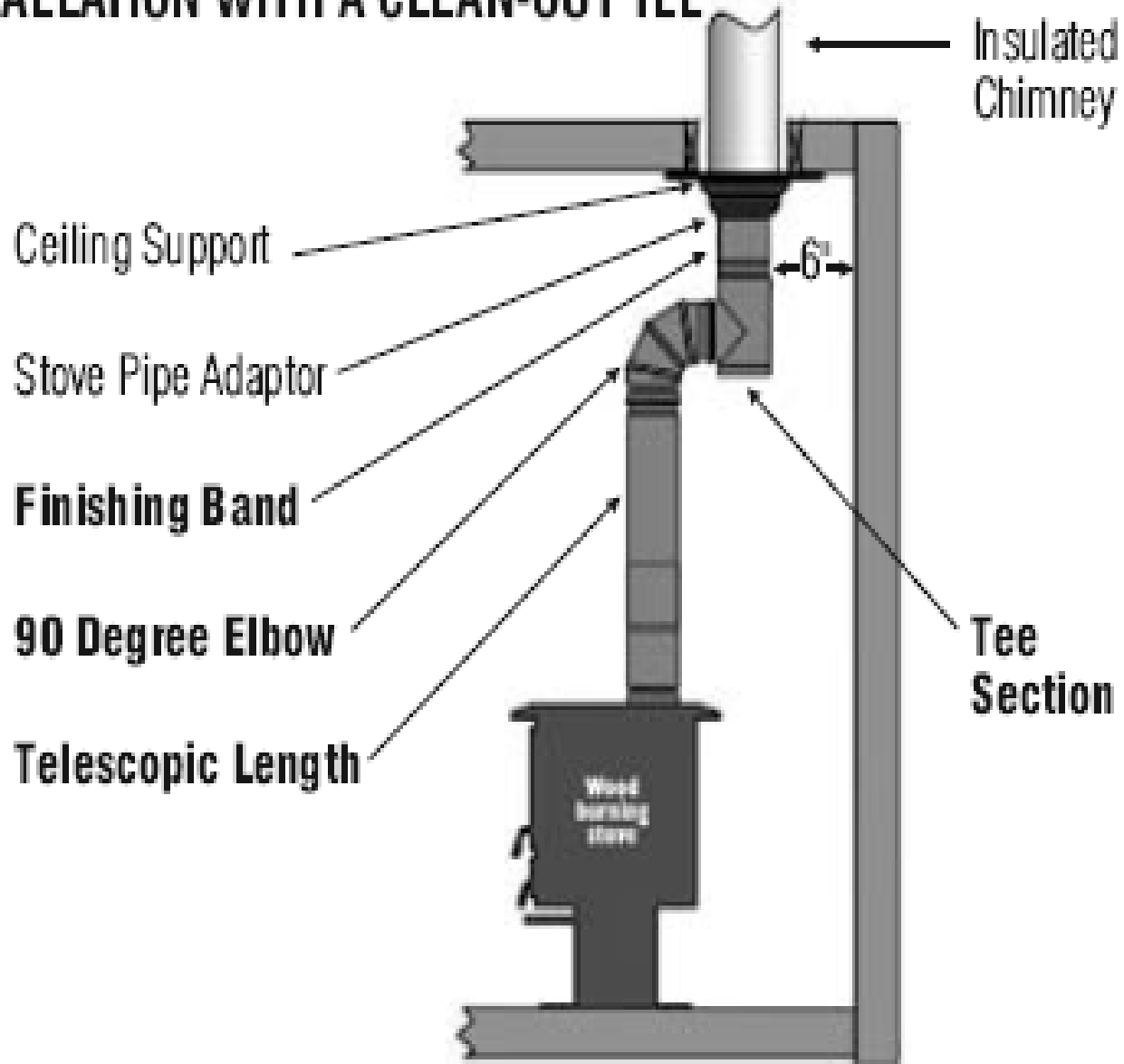



- ***Modern, efficient appliances need modern, efficient chimneys. The selection, location and installation of the chimney is at least as important as the type of wood-burning appliance you choose. A properly designed and installed chimney will give many years of reliable service and will allow your appliance to perform properly.***



## **THE CHIMNEY**

**The chimney's function is to produce the draft that draws combustion air into the appliance and safely exhaust the gases from combustion to the outside.**

- To fulfill this role, the chimney must:
- isolate nearby combustible materials from flue gas heat;
- tolerate the high gas temperatures that can result from chimney fires;
- conserve flue gas heat to produce strong draft;
- be resistant to corrosion on the inside and to weather effects on the outside; and
- be sealed to prevent leakage.

## **MINIMUM CHIMNEY HEIGHT ABOVE THE ROOF AND CLEARANCE FROM NEARBY OBSTACLES**

- The top of a chimney should be high enough to be above the air turbulence caused when wind blows against the house and its roof. The chimney must extend at least 1 m (3 ft.) above the highest point of contact with the roof, and at least 600 mm (2 ft.) higher than any roof line or obstacle within a horizontal distance of 3m (10ft.).*

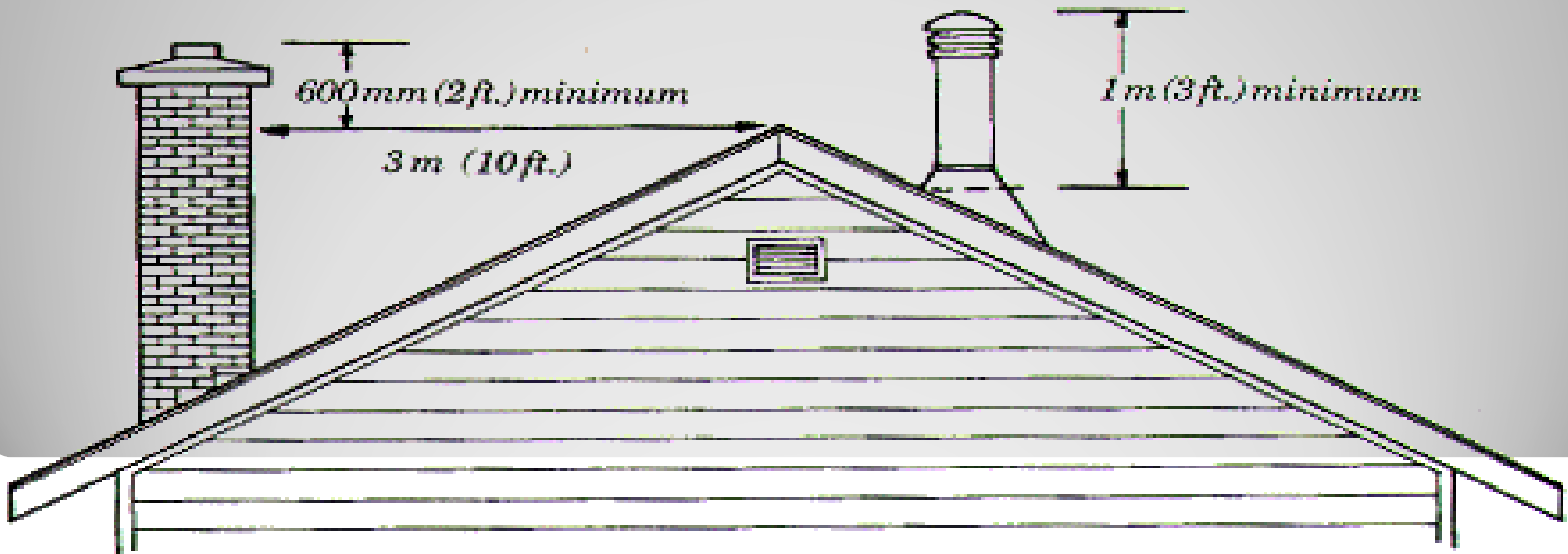

## Factory-built metal chimneys

### ***THE 650°C FACTORY-BUILT CHIMNEY***

- This type of chimney was developed to withstand the high temperatures produced by a chimney fire. The thicker insulation compared to other factory-built chimneys is needed to isolate nearby combustible material from the high gas temperatures in the flue.*

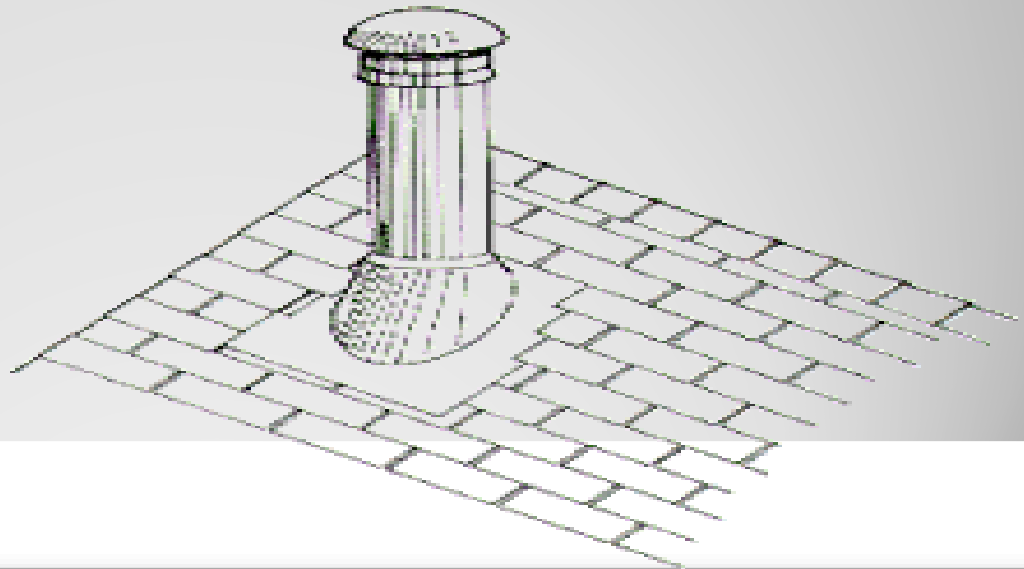

# *Unsuitable Chimneys*

- **Type A chimneys:** The type of metal chimney used before 1981 is not considered suitable for wood-burning appliances. **Called Type A**, this chimney was originally designed for oil furnaces and is unable to withstand the high temperatures that may occur during a chimney fire.
- **Type A chimneys** normally had a 25 mm (1 in.) wall thickness and were available with both cylindrical and square section outer casings. If you have an existing wood-burning system using a Type A chimney, you should consider upgrading it to the new 650°C chimney as soon as possible. If it cannot be changed right away, you should have it cleaned and inspected by a qualified chimney sweep to determine if it is still safe to use. Deteriorated metal chimneys can be hazardous.
- **Bracket masonry chimneys:** Masonry chimneys that are not supported on proper concrete foundations should not be used. Called bracket chimneys, these are brick chimneys that are built on wooden supports within a wall of the house. They are common in older houses, particularly in rural areas. Bracket chimneys cannot be upgraded to meet current building code requirements and should be replaced.

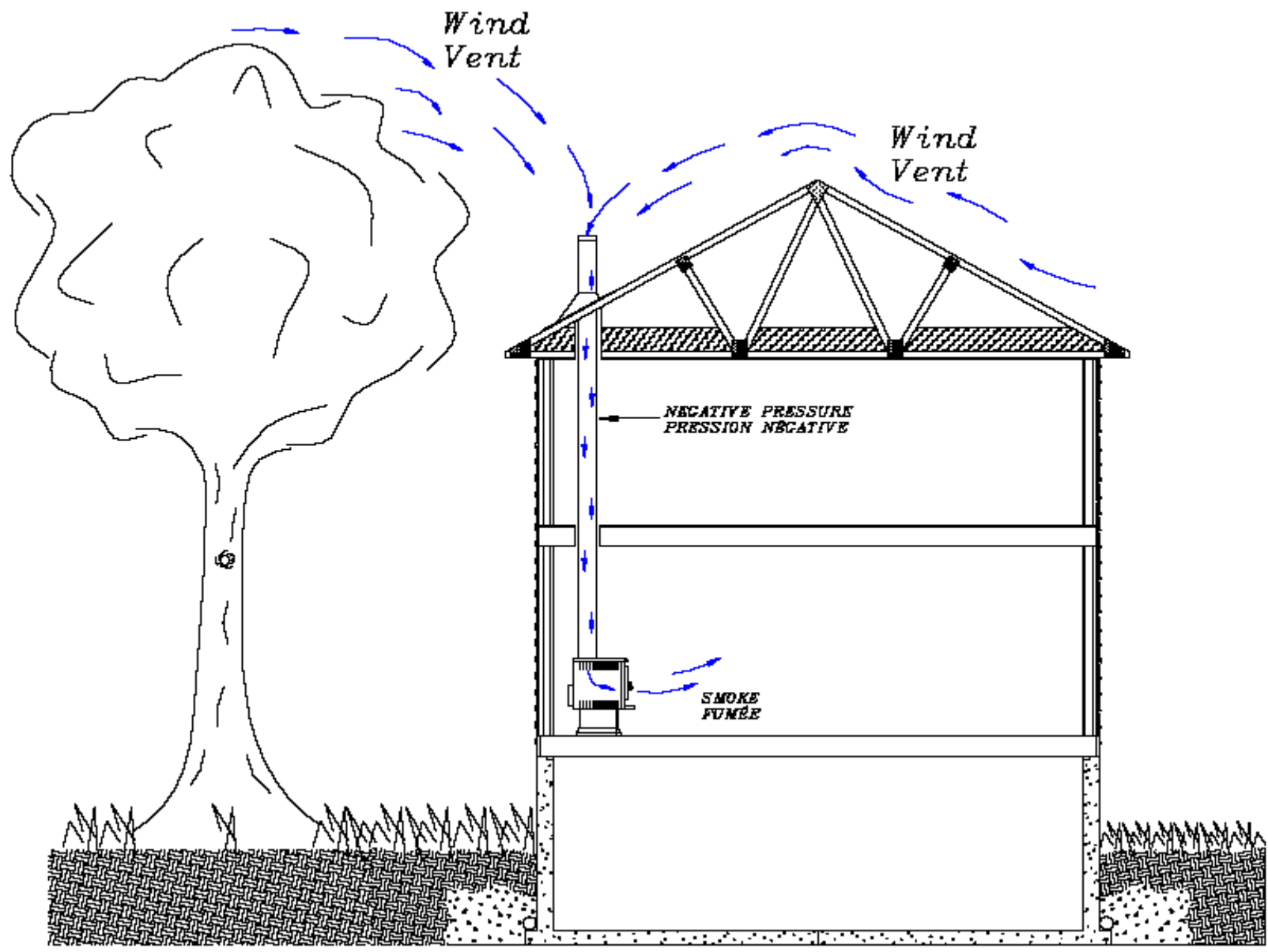

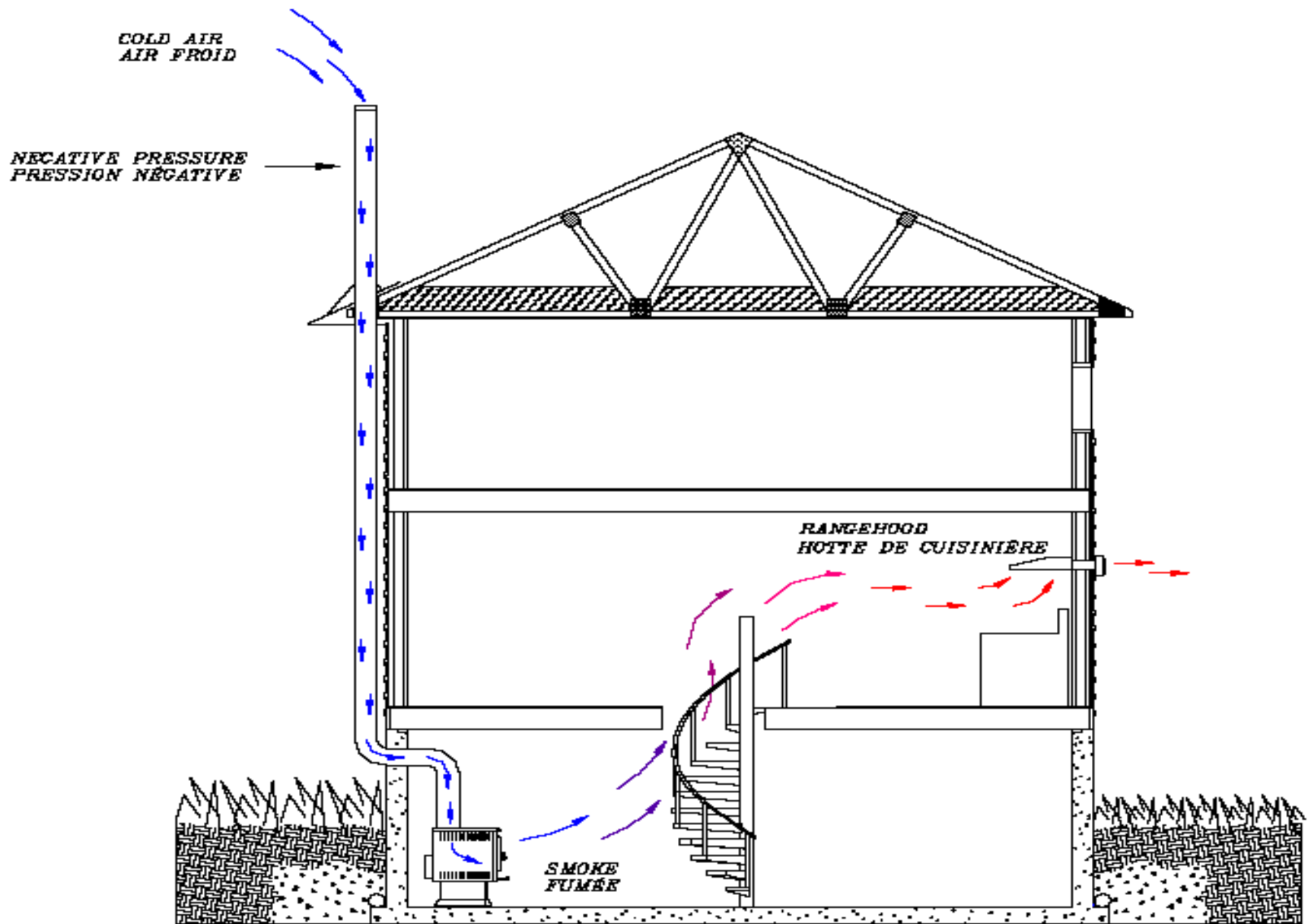

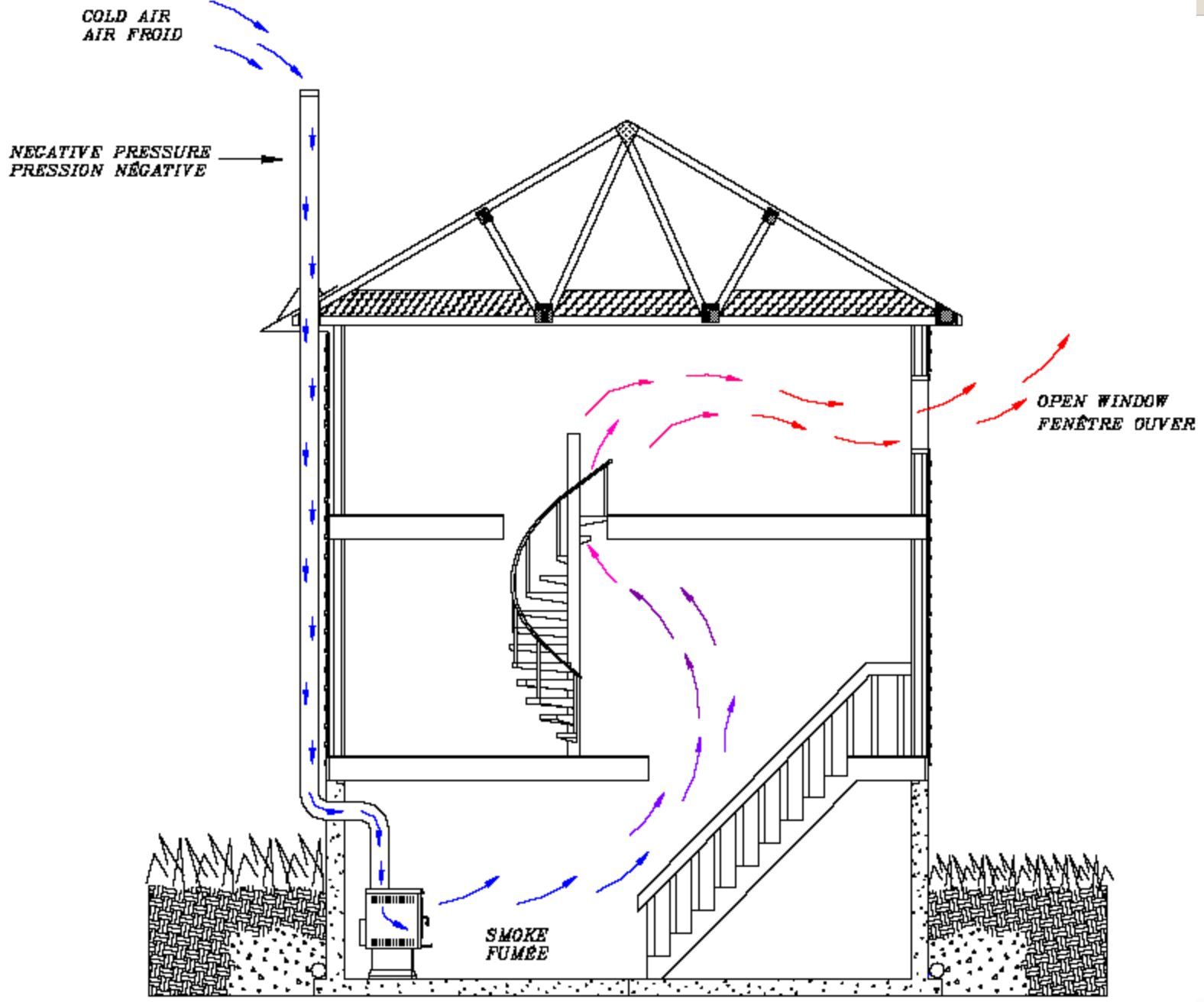



*NORMAL COMBUSTION  
COMBUSTION NORMALE*

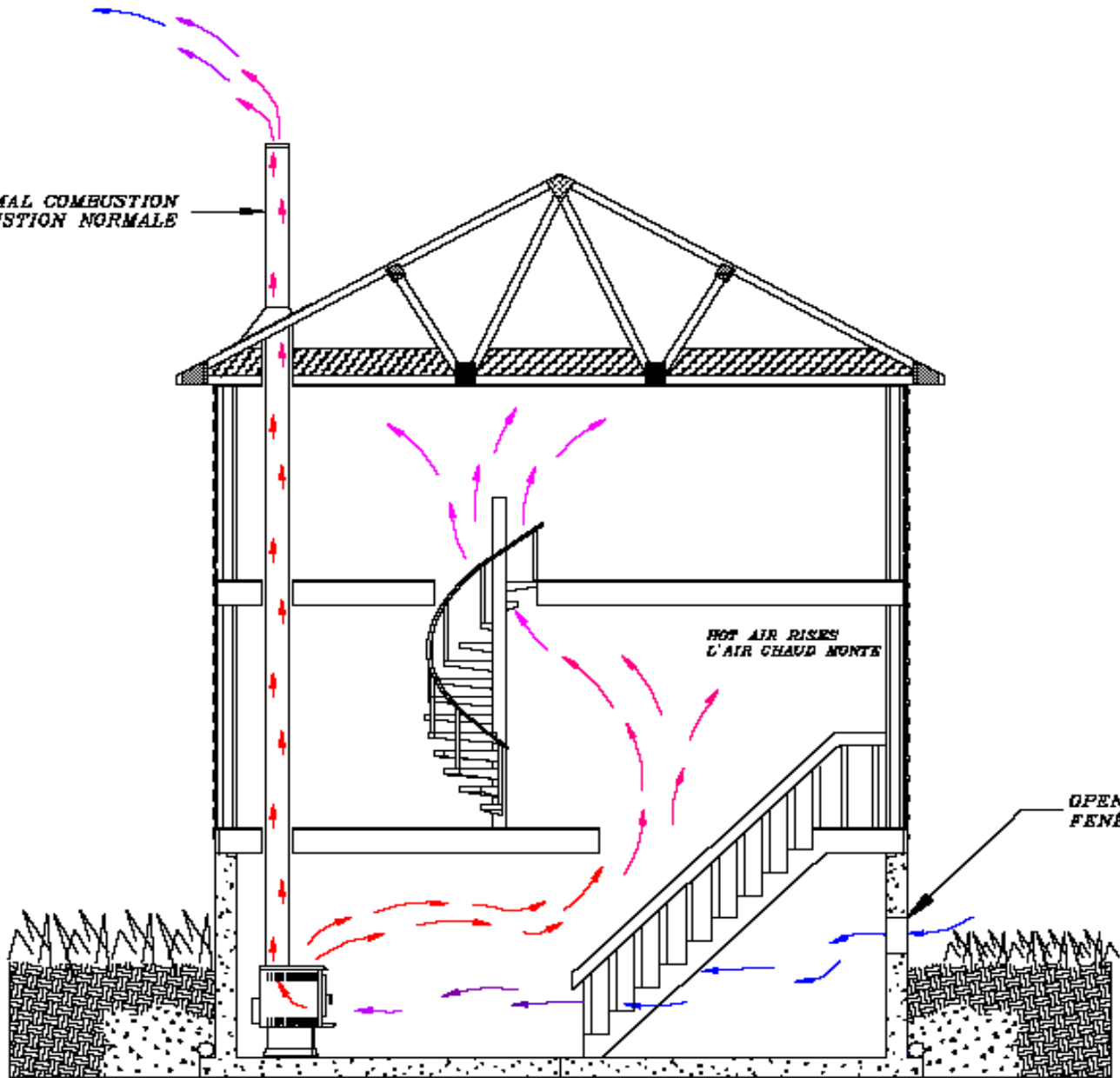

*HOT AIR RISES  
L'AIR CHAUD MONTE*

*OPEN WINDOW / AIR INTAKE  
FENÊTRE OUVERTE / PRISE D'AIR*

# Chimney fires are the result of poor appliance firing technique combined with a lack of proper chimney maintenance.

- When wood-burning appliances are operated properly using the techniques some creosote may still be deposited, but it will be of a less combustible type. Instead of the black, tarry type of creosote that results from smoldering fires, the creosote that results from proper firing is soft, flaky and dark brown in color.

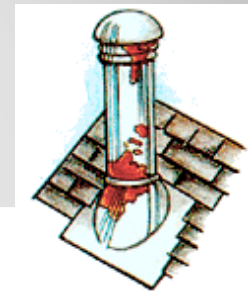

# Tested to 2100 degrees UL Listed - 10 Year Warranty

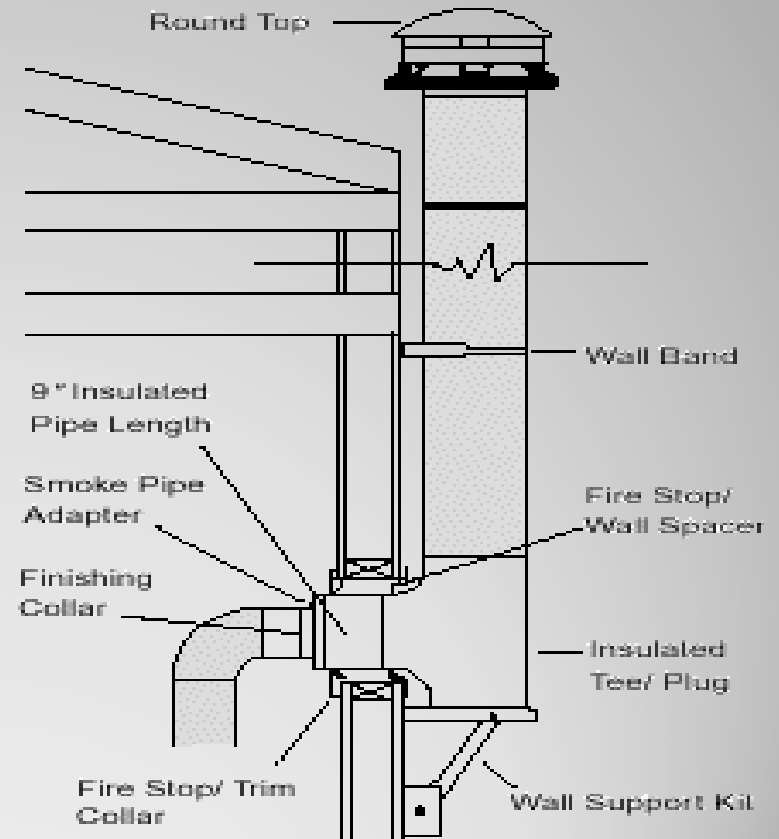

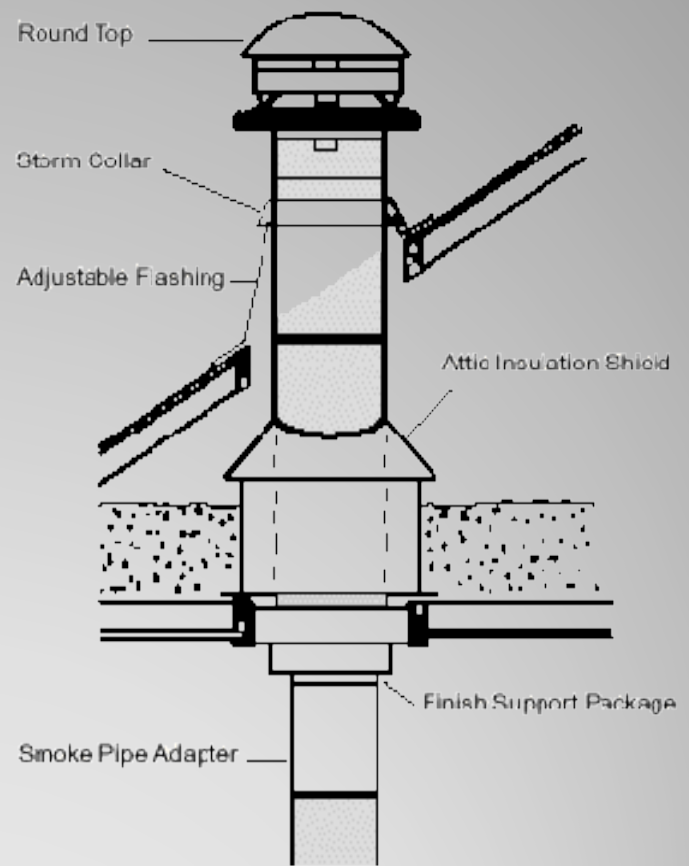
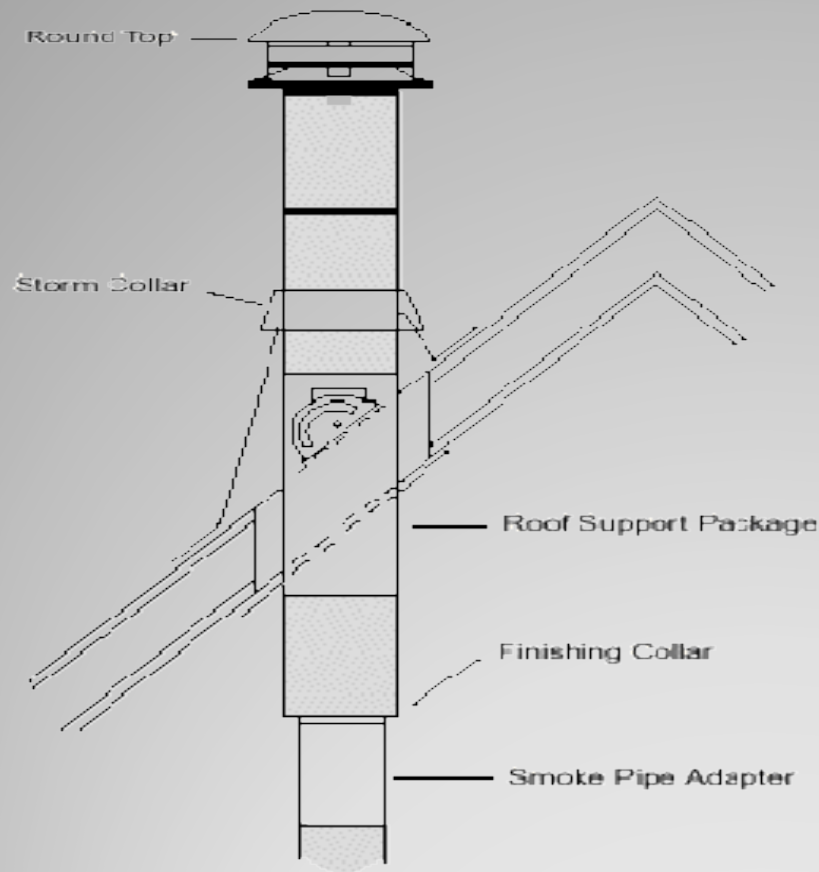

**Tested to 2100 degrees UL Listed - 10 Year Warranty**

## CONNECTION TO A FACTORY BUILT CHIMNEY

The room heater may be connected to a listed factory-built chimney which complies with the requirements of UL 103HT (USA) or CAN/ULC S629 (Canada). Check with your local regulatory authority for specific requirements. Follow the chimney manufacturer's instructions when installing a factory-built chimney.

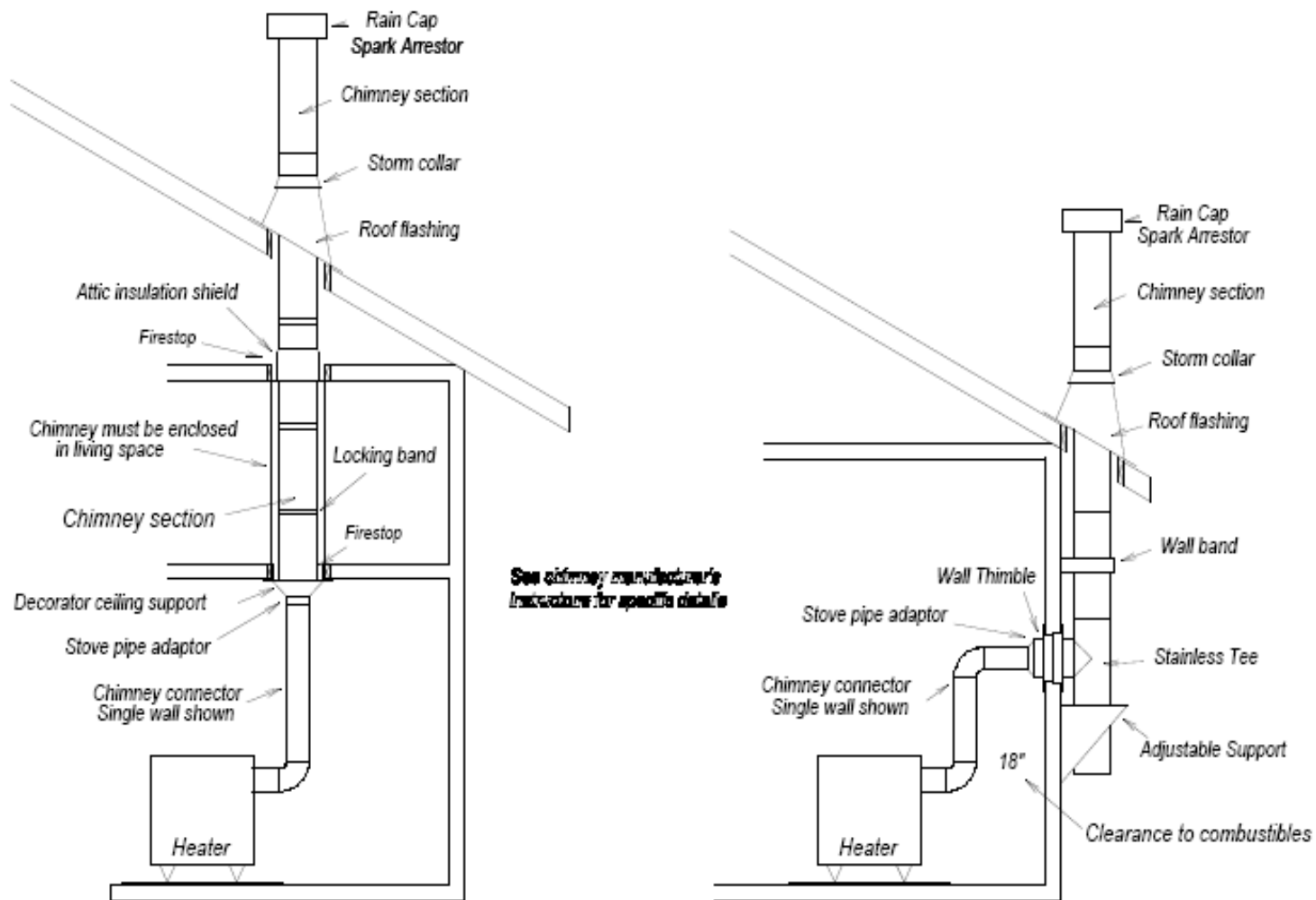

TYPICAL FACTORY BUILT CHIMNEY INSTALLATION

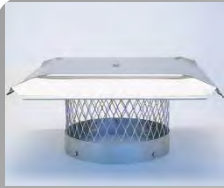

# Chimney Caps



## Three reasons every chimney needs a cap:

1. **Rain protection** - water causes the greatest damage to your chimney of any of the elements. It soaks into the porous bricks, eats away at the mortar, hastens the destruction of the chimney liner, and destroys the chimney crown. A chimney cap does a great job of protecting your chimney from water damage. For maximum chimney protection a recommendation of a multi-flue cap. That's because a multi-flue cap covers the entire chimney, not just one flue.
2. **Animal protection** - one of the great sources of danger to homeowners is the threat of disease from animals like raccoons, squirrels, birds, and rodents that make their home in their chimneys. A well-made chimney cap will keep those animals out of your home. Sturdy mesh and a strong lid keep even the most determined critters at bay.
3. **Spark protection** the mesh screen on our caps protects your home from sparks emitted from your chimney. That means less danger of a fire caused by stray sparks from your fireplace or wood stove.

# Chimney Maintenance

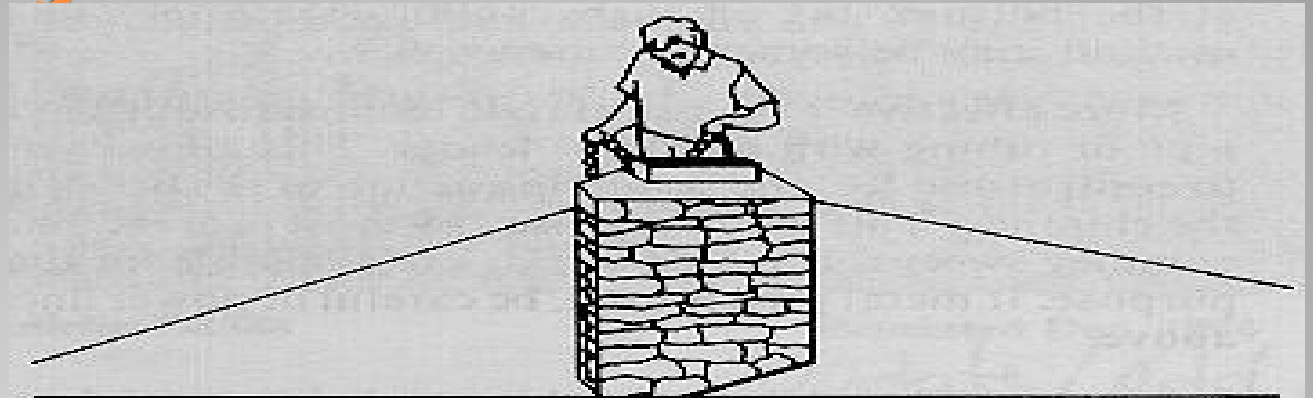
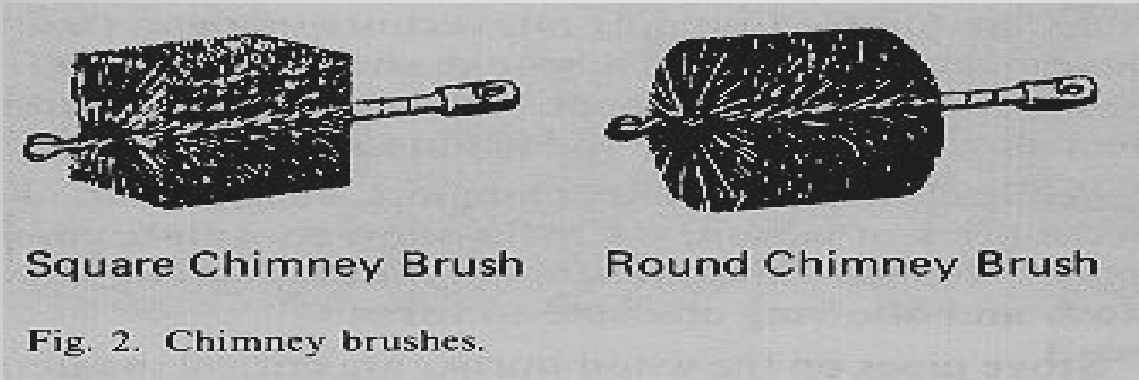

Fig. 3. Chimneys can be cleaned with a bag filled with rocks or chains or with a professional stiff wire brush.



Square Chimney Brush

Round Chimney Brush

Fig. 2. Chimney brushes.

# CARBON MONOXIDE

Carbon monoxide is a very powerful and deadly poison. One part of carbon monoxide in 5,000 parts of air will produce a 20% blood carbon monoxide level in approximately 1 hour

**Fireplace or Wood Stove.** Burning wood, wood pellets, coal, or gas logs with a closed or broken flue damper, blocked or cracked chimney or flue, or a bird or other animal nest blockage all may cause carbon monoxide intrusion into the room. In addition, the great quantity of draft up the chimney, early and throughout most of the burning process, may cause other fuel burning appliances to back-draft, particularly those equipped with draft hoods. Late in the fireplace or wood stove burnout process, the emissions of carbon monoxide tend to increase; at about the same time, the natural draft decreases. This condition may allow carbon monoxide from the fireplace or wood stove to now back-draft into the room, if other fuel burning appliances, or exhaust fans are operating, or even if down-wind windows are opened. Leave the flue damper open long after the fire is out and the ashes are cold. Closing the flue damper too early may divert the carbon monoxide into the room.



# Smoke Alarms & Installing Smoke Alarms

1. Choose smoke alarms that have the label of a recognized testing laboratory.
2. Install smoke alarms inside each bedroom, outside each sleeping area and on every level of the home, including the basement.
3. On levels without bedrooms, install alarms in the living room (or den or family room) or near the stairway to the upper level, or in both locations.
4. Smoke alarms installed in the basement should be installed on the ceiling at the bottom of the stairs leading to the next level.
5. Smoke alarms should be installed at least 10 feet (3 meters) from a cooking appliance to minimize false alarms when cooking. Not Suggested
6. Mount smoke alarms high on walls or ceilings (remember, smoke rises). Wall-mounted alarms should be installed not more than 12 inches away from the ceiling (to the top of the alarm).
7. If you have ceilings that are pitched, install the alarm within 3 feet of the peak but not within the apex of the peak (four inches down from the peak).

# QUESTIONS??

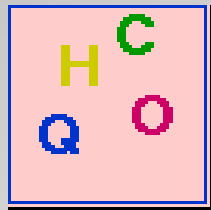

?

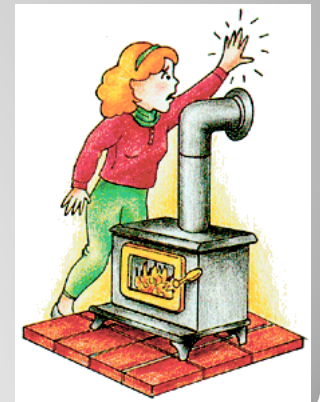
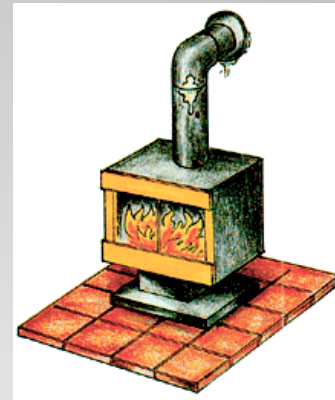

# Acknowledgements

- Wood Energy Technical Training Reference Manual
- National Resource Canada-Residential Wood Heating Guide
- CMHC
- B365-2010 Solid Fuel Burning Appliance
- National Building Code Of Canada
- NFPA 211 Chimney Fireplaces and Solid Fuel-Burning Appliances.